



ARRI TECHNICAL NOTE P-1019

ARRIMAG 300E “Not Ready” August 1, 2000

Summary

This note lists the conditions that can lead to the “ARRIMAG 300E Not Ready” status on a 435, plus describes a way to test the 435 and the ARRIMAG 300E without film.

ARRIMAG 300E Not Ready

If a problem with the ARRIMAG 300E (the torque motor driven 1000' magazine for the 435) prevents the 435 from running, the camera's RUN LED will glow red, and the second digit on the top line of the display will turn into an underline (see graphic). This is the “ARRIMAGE 300E Not Ready” status, which could be caused by one of the following 5 conditions.

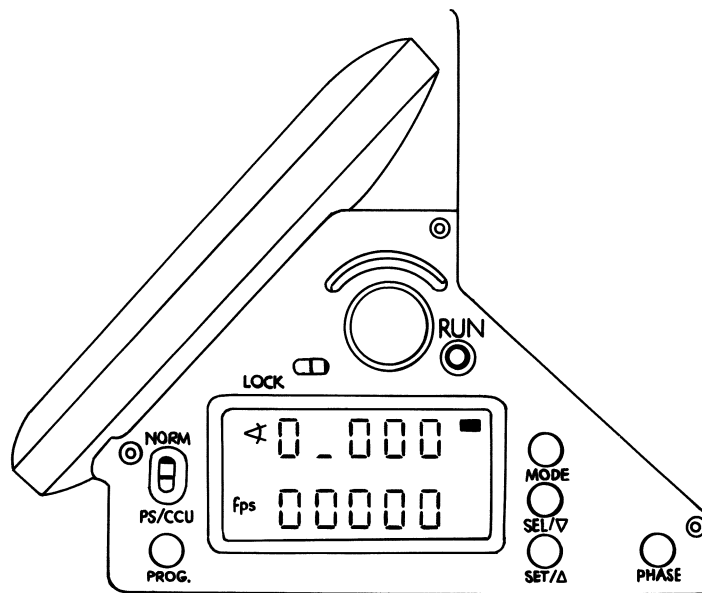

1. No Core

There is no core on the feed and/or the take up shaft, or the roller arm is trapped underneath a core (the roller arm senses the film roll size).

Action: Lift the roller arm up and make sure both cores are present and pushed all the way onto the shafts. The “not ready” status should end and the magazine should start tensioning take up and feed side.

2. Roller Arm is in Loading Position

One roller arm is still locked in the loading position.

Action: Make sure both roller arms are unlocked. The “not ready” status should end and the magazine should start tensioning take up and feed side.

3. Film Cannot be Wound Up

After the magazine is powered up, it will attempt to wind up any loose film on both the take up and the feed side. If either side still rotates after 30 seconds, the magazine will go into “not ready” status. This can occur if either there was a lot of loose film in the magazine or if the film has not been securely attached to the take up side core.

ARRI TECHNICAL NOTE P-1019

Action: If you suspect that there was a lot of loose film, tighten the loose film by hand. This can be done by pushing in on the magazine clutch covers and by rotating the clutch covers. When looking at the magazine from the camera right, turn the right clutch cover clockwise, and the left clutch cover counterclockwise. If you do not feel any resistance on the take up side after a while, you should take the magazine back into the changing bag and make sure that the film end is securely attached to the take up core. Once the film is properly wound up on both sides, the camera has to be reset by either turning its power off and on again, or by removing and re-attaching the magazine.

4. Film End

The “1000’ ARRIMAG Not Ready” condition will also occur when the camera runs out of film. The camera will stop running and the LCD display will show END.

Action: Take the magazine off the camera and attach a new one with fresh raw stock.

5. No Magazine Communication

If the camera cannot communicate with the magazine, it goes into the “1000’ ARRIMAG Not Ready” status. The cause could be dirt on the 4 gold contacts between the magazine and the camera, or an internal camera error.

Action: If you see dirt on the camera’s or the magazine’s contacts, clean it with contact cleaner. If no dirt is visible, all previously noted conditions have been excluded, and the same problem occurs with more than one 1000’ ARRIMAGs, it could be a camera internal error. In that case, contact your local ARRI service facility.

Testing Without Film

It is possible to test the operation of the 435 with a 1000’ magazine even if no film is loaded. Make sure a core is on both the take up and the feed side of the magazine, attach the magazine to the camera and power the camera up. After attempting to wind up any loose film for 30 seconds, the magazine will notice that no film is loaded but both cores are present, and go into a test mode. In the test mode the magazine spindles will always turn at a slow rate, disregarding the camera’s speed.

For more information on this issue, please contact your local ARRI representative.